

CONSTRUCTION NOTES:

A) MATERIALS ARE ALL WELDED 316L STAINLESS STEEL

B) HEAT TRANSFER AREA IS APPROXIMATELY 5.0 SQUARE FEET

C) CONNECTION PORTS ARE 2 OF 3/4" NPT AND 2 OF 1" NPT

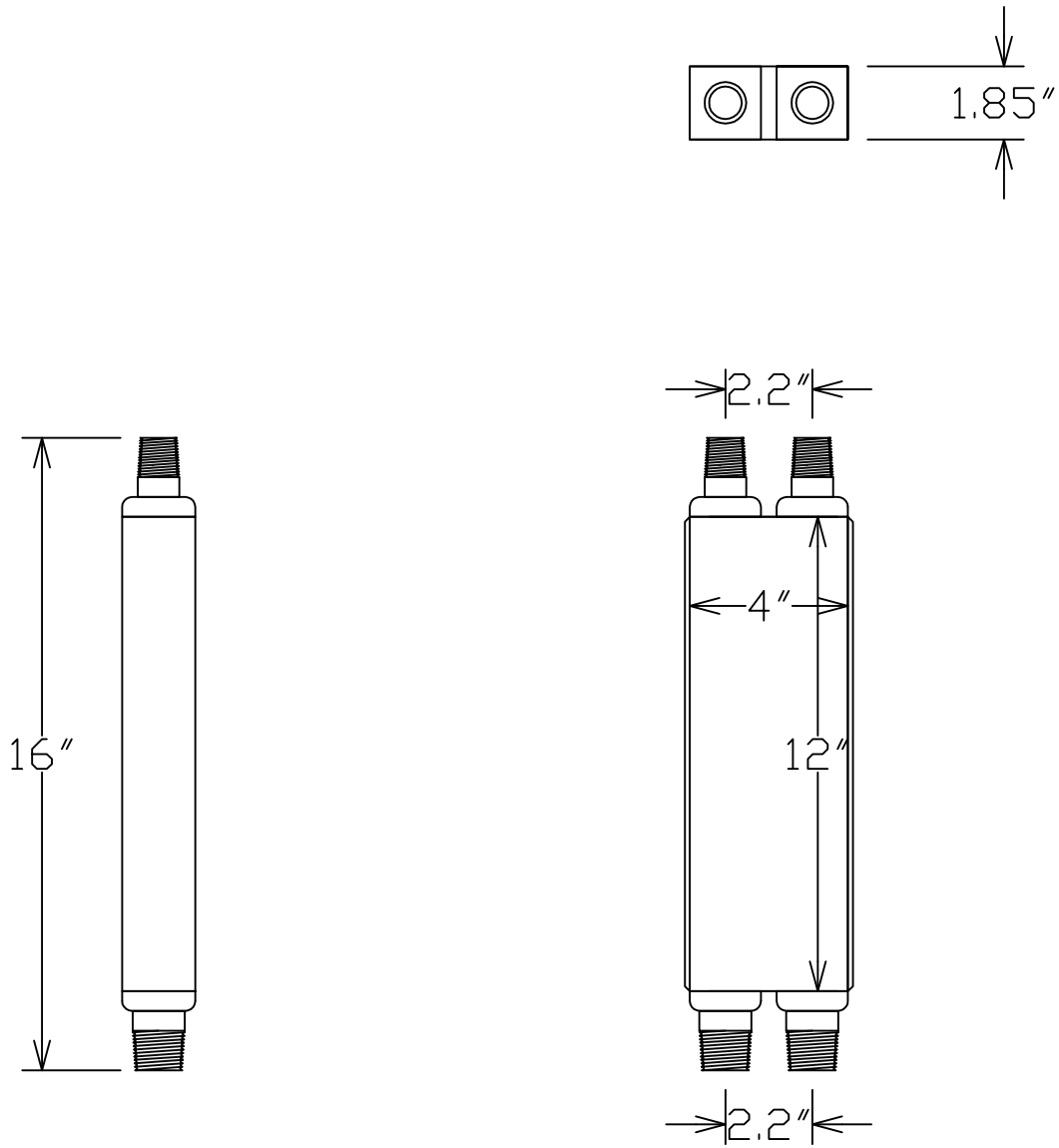

Carlson
HEAT EXCHANGER

MODEL:
5.0 C

<http://CarlsonHX.com>
Copyright 2011
Carlson Heat Exchanger